

# SURFACES

LINE SURFACES 016  
SUR-LNE-016



PRODUCT GUIDE



**WOOL FELT**

100% organic premium design felt.



**POWERFUL ACOUSTICS**

High Noise Reduction Coefficient.



**FIRE-SAFE**

ASTM E84: Class A tested and compliant.



**VOC FREE**

CDPH Standard Method V1.2 School Classroom and Private Office Compliant.



**CUSTOM SIZING**

Custom-sized products arrive installation ready.



**SUSTAINABILITY**

100% organic wool is harvested without animal harm.



**LOW MAINTENANCE**

A light dusting is all you'll ever need.



**TACTILE EXPERIENCE**

Soft, plush felt delivers unbeatable touch experience.



**LEAD TIME**

2-4 weeks with vast color options.



# SPECIFICATIONS

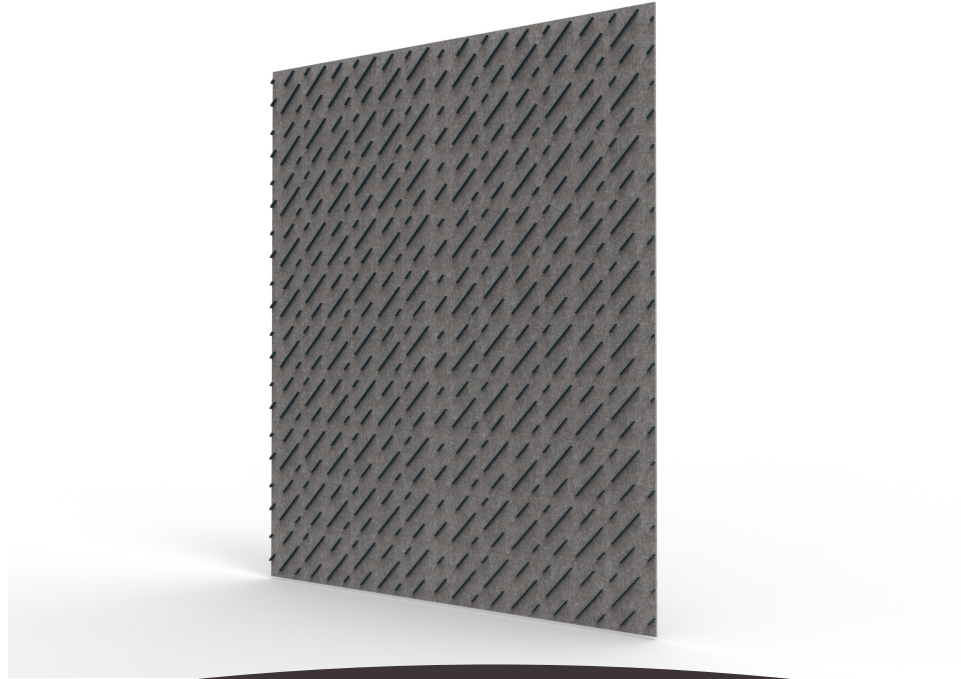

<b>PRODUCT ID</b>	SUR-LNE-016
<b>CONTENT</b>	PoshFelt® 100% organic wool design felt
<b>DURABILITY</b>	Impact resistant, shock absorbant
<b>WEATHERING</b>	Non-deteriorating, non-hygroscopic, colorfast
<b>MAINTENANCE</b>	Clean with vacuum or light dusting
<b>WARRANTY</b>	Comes with industry-leading standard warranty
<b>ENVIRONMENTAL</b>	100% biodegradable/compostable, contains no formaldehyde, 100% VOC free, no chemical irritants, and free of harmful substances
<b>INSTALLATION</b>	CSI Installation Systems are product specific (see Installation page)
<b>ACOUSTICS</b>	0.60 NRC
<b>FLAMMABILITY</b>	ASTM E84: Class A

# TECHNICAL

## LENGTH

48"  
*custom lengths available*

## WIDTH

1"  
*custom widths available*

## HEIGHT

108"  
*custom heights available*

## MATERIAL THICKNESS

1/8" and 5/8"  
*custom thicknesses available*

## SPACING

Varies  
*custom spacing available*

## EDGE

Exposed or covered

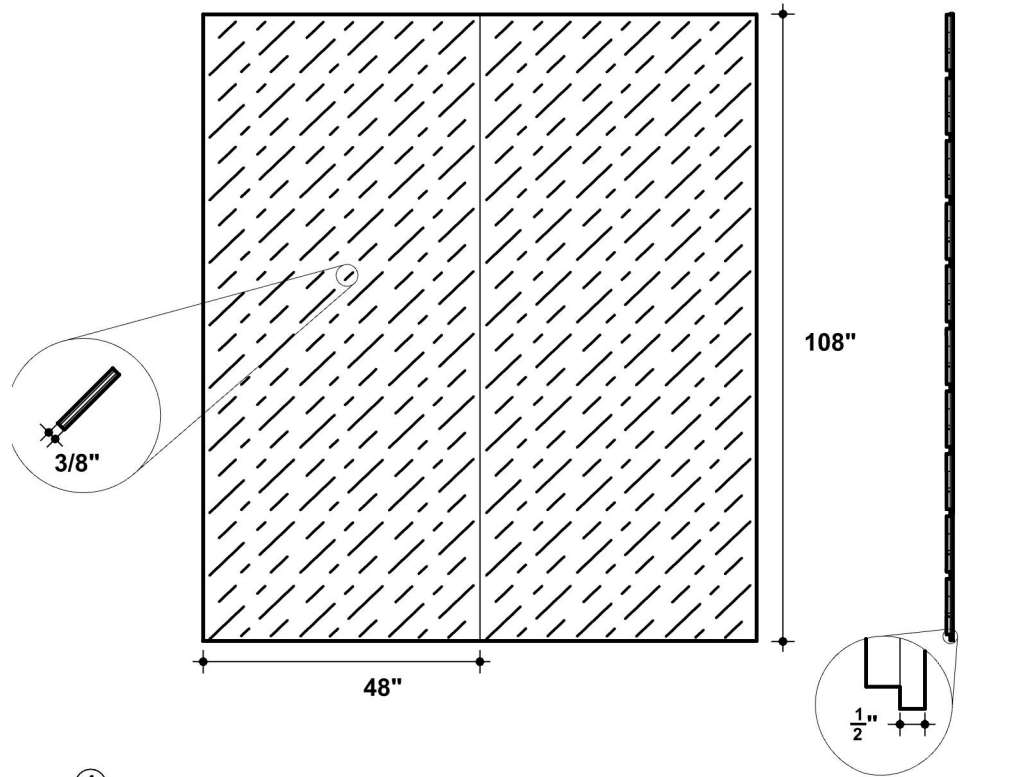

①



② TOP VIEW

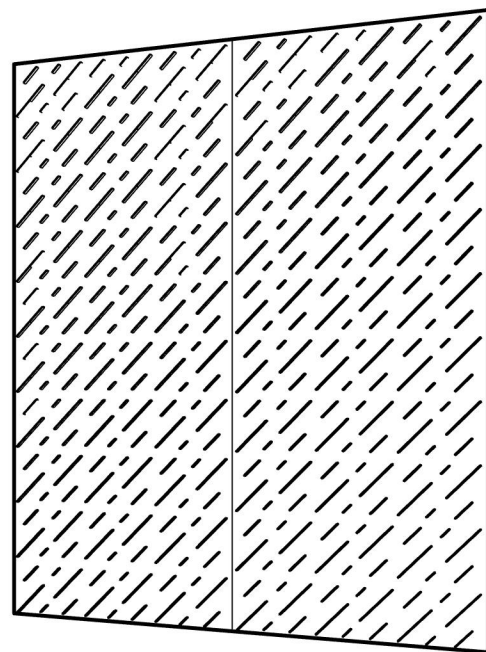

③ PERSPECTIVE VIEW



# INSTALLATION

Surface installation systems are designed according to site conditions, and maximize efficiency of installation.

Each solution respects the integrity of the project design, budget, and installs easily with simple tools.

## DIRECT ATTACHMENT SYSTEM

Attachment solution for pre-constructed ceiling substrates using construction adhesives. Requires minimal skilled installation labor. Ideal for remodeling spaces.

## PEEL AND STICK SYSTEM

Attachment solution for existing surfaces or substrates using pre-applied adhesive backing. Requires minimal skilled installation labor - simply peel, and stick.

## INDIVIDUAL CLIP SYSTEM

Attachment system for hanging multiple panels in series efficiently. Maintains alignment of panels with a drop-in gravity clip system. Easily installed in post-construction phase.

## SNAP MOUNT SYSTEM

Attachment system for efficient installation via pre-designed modular configurations using snap-locking hardware. Engage us in the design phase for site-specific templates and hardware configurations.

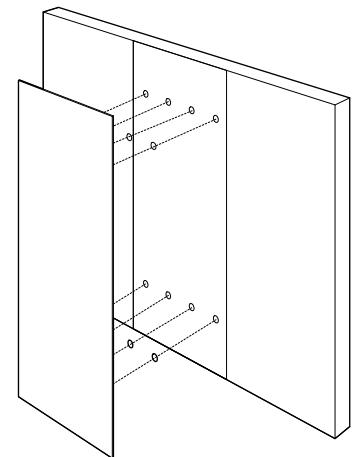
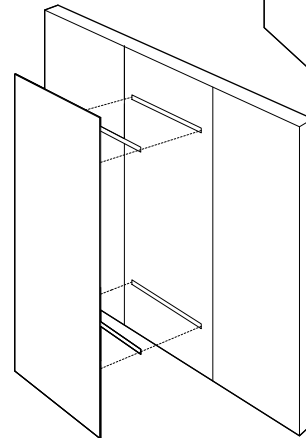
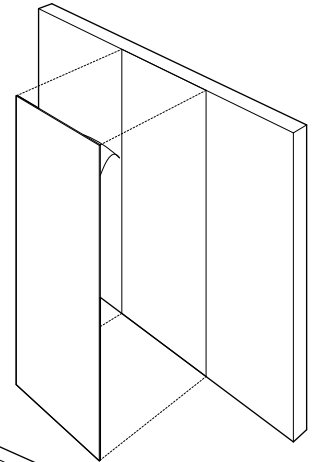
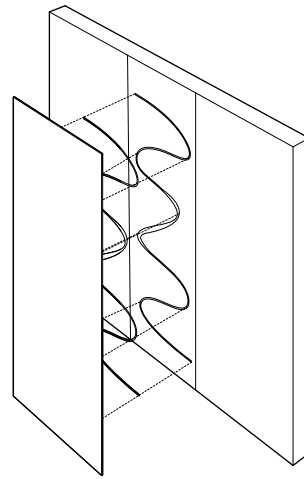

# SITE CONDITIONS

## TRANSITION

Surface installations in transition areas are typically simple, low-profile cladding that uses color to assist in wayfinding, and enhances the acoustics of hard surfaces in hallways.

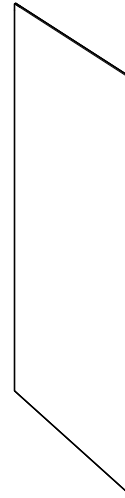

## FOCAL POINT

Surface cladding used as a focal point can be infinitely more complex, and can integrate other materials. A focal point gets much more visual attention than transition spaces, and serves artistic merit as well as acoustics.

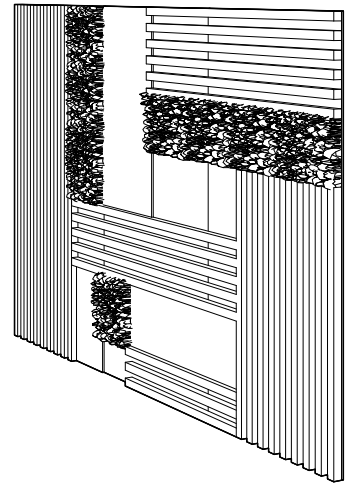

## BRANDING

Any product can be designed with integrated branding opportunities, from color choices to lettering, carving, graphic displays and more.

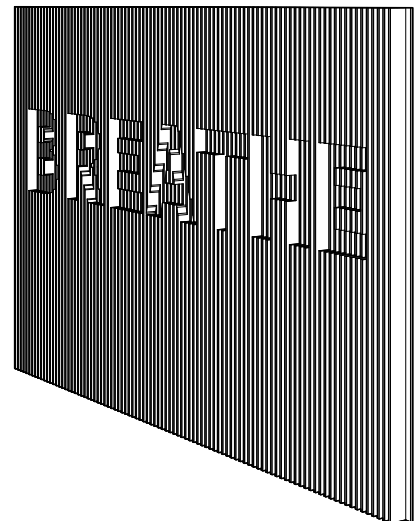

# COLORWAYS

POSHFELT® 100% ORGANIC WOOL DESIGN FELT





**BASE LAYER RECYCLED PET ACOUSTIC FELT**

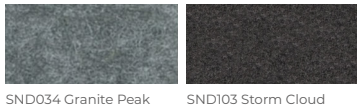



# SUSTAINABILITY



## WHY WOOL?

Wool has a strong track record. As in, thousands of years strong. The first instances of wool as a textile date back to 1500 BC, and for great reason: wool is a sustainable source of workable fiber, harvested without any harm to the animal.

Wool is cleaned and refined into a more cooperative felt product with an array of natural features, including wrinkle resistance, anti-static, high burning point, insulative properties, shock resistance—the list goes on.

## MATERIAL CONSTRUCTION

100% organic Merino or Karakul Wool

## PRODUCT CERTIFICATIONS

ASTM E84: Class A, VOC Free (CDPH Standard Method V1.2)



# OUR MISSION

---

## EXPERIENTIAL SPACES

Our goal is to create spaces that feel better.

It's easy to visualize a space with architectural acoustics, but even the most detailed renderings couldn't convey the experience of actually being there. When sound is properly controlled within a space, it creates focus and calmness that you can actually feel. We want to help you turn off the droning machinery in the back of your mind. We fabricate custom solutions that visually suit your space while building towards a more soothing holistic experience. This creates spaces where people want to be—where they want to work, where they want to sleep, exercise, create, study, and relax.

